

COOPERATIVE OUTPUT-FEEDBACK CONTROL OF NONLINEAR MULTI-AGENT SYSTEMS

Zhong-Ping Jiang

New York University

Joint work with T. Liu

BIT Workshop, July 24, 2014

WHAT'S NEW IN OUR WORK?

- Non-identical agents;
- Nonlinear, higher-dimensional models;
- Distributed output-feedback vs. state-feedback

OUTLINE

- Motivation and Problem Statement
- Tools: ISS and Network Small-Gain Theory
- Solution to Distributed Output-Feedback Control
- Conclusions

DISTRIBUTED CONTROL STRUCTURE

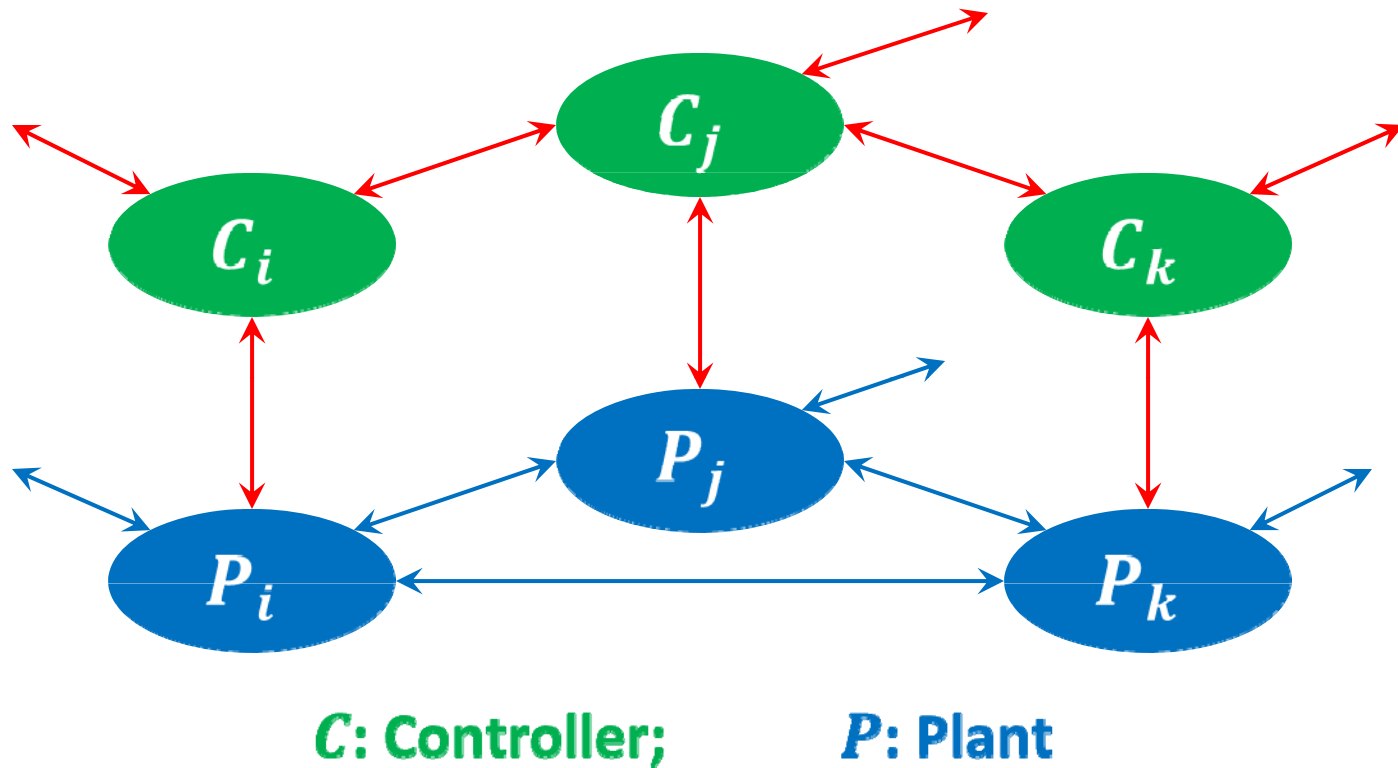

↔ Communication links for coordination

↔ Physical interconnections or autonomous

Basic Idea:

Transform a distributed control problem into a stabilization problem of dynamic networks:

- Nonlinear dynamics
- Uncertainties
- Time-delay

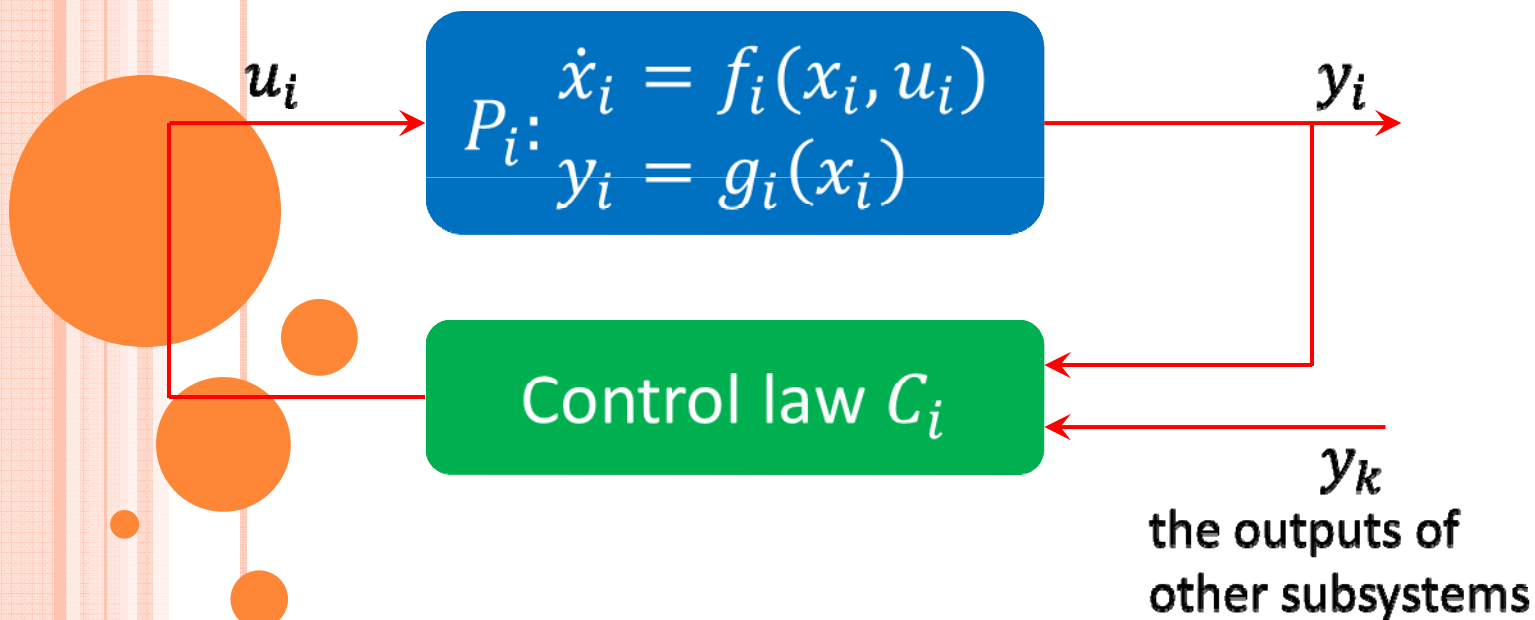

INPUT-TO-STATE STABILITY (ISS)

Consider a nonlinear control system

$$\dot{x} = f(x, u)$$

where $f : \mathbb{R}^n \times \mathbb{R}^m \rightarrow \mathbb{R}^n$ is a locally Lipschitz function and satisfies $f(0, 0) = 0$.

The system is said to be ***input-to-state stable*** (ISS) if

$$\|x(t)\| \leq \max \{ \beta(\|x(0)\|, t), \gamma(\|u\|_\infty) \}$$

for all $t \geq 0$, where $\beta \in \mathcal{KL}$ and $\gamma \in \mathcal{K}$. Function γ is called ISS gain. $\|\cdot\|_\infty$ stands for the *essential supremum norm*.

[Sontag, TAC' 89, 90]

ISS, NONLINEAR SMALL-GAIN THEOREM

Consider an interconnected system

$$\dot{x}_1 = f_1(x_1, x_2, u_1)$$

$$\dot{x}_2 = f_2(x_2, x_1, u_2)$$

Assume that each x_i -subsystem is ISS:

$$|x_i(t)| \leq \max \left\{ \beta_i(|x_i(0)|, t), \gamma_{i(3-i)}(\|x_{3-i}\|_\infty), \gamma_i^u(\|u_i\|_\infty) \right\}$$

where $\beta_i \in \mathcal{KL}$, $\gamma_{i(3-i)}, \gamma_i^u \in \mathcal{K}$.

The interconnected system is ISS with (u_1, u_2) as the input if

$$\gamma_{12}(\gamma_{21}(s)) < s, \quad \forall s > 0,$$

i.e.,

$$\gamma_{12} \circ \gamma_{21} < \text{Id}.$$

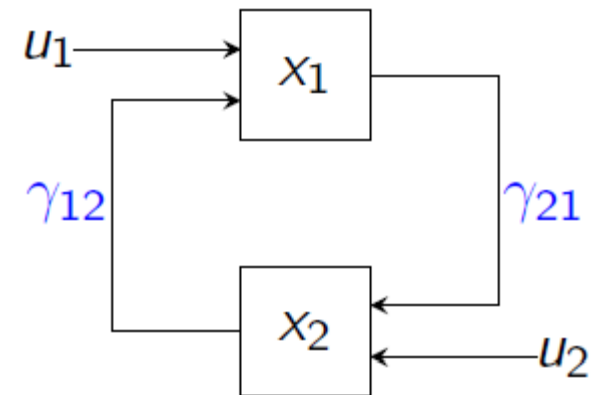

SMALL-GAIN THEOREM FOR INPUT-TO-OUTPUT STABLE (IOS) SYSTEMS

Consider an interconnected system composed of two subsystems: for $i = 1, 2$,

$$\dot{x}_i = f_i(x_i, u_i, y_{3-i}), \quad y_i = h_i(x_i).$$

Assume that each subsystem is *unboundedness observable* (UO) with zero-offset and IOS:

$$|x_i(t)| \leq \alpha_i^o \left(|x_i(0)| + \|y_{3-i}\|_{[0,t]} + \|u_i\|_{[0,t]} \right)$$

$$|y_i(t)| \leq \max \left\{ \beta_i(|x_i(0)|, t), \gamma_{i(3-i)}(\|y_{3-i}\|_\infty), \gamma_i^u(\|u_i\|_\infty) \right\}$$

The interconnected system is UO and IOS with (u_1, u_2) as the input if

$$\gamma_{12} \circ \gamma_{21} < \text{Id.}$$

More general results on systems with *input-to-output practical stability* (IOpS) properties can be found in [Jiang, Teel & Praly' 94].

NETWORK SMALL-GAIN THEOREMS

Consider a large-scale dynamic network: for $i = 1, \dots, n$,

$$\dot{x}_1 = f_1(x_1, y_2, y_3, \dots, y_n, u_1)$$

$$\dot{x}_2 = f_2(x_2, y_1, y_3, \dots, y_n, u_2)$$

\vdots

$$\dot{x}_n = f_n(x_n, y_1, y_2, \dots, y_{n-1}, u_n)$$

with output maps

$$y_i = h_i(x_i).$$

Assume that each i -th subsystem is UO with zero-offset and IOS with u_i, y_j ($j \neq i$) as the inputs and y_i as the output.

Specifically, there exist $\beta_i \in \mathcal{KL}$, and $\gamma_{ij}, \gamma_i^u \in \mathcal{K} \cup \{0\}$ such that

$$\|y_i(t)\| \leq \max_{j \neq i} \left\{ \beta_i(\|x_i(0)\|, t), \gamma_{ij}(\|y_j\|_{[0,t]}), \gamma_i^u(\|u_i\|_\infty) \right\}$$

“Vector small-gain”, see Karafyllis/ZPJ’ 11

HERE, WE PRESENT ONLY “CYCLIC-SMALL-GAIN” THEOREM

$$\|y_i(t)\| \leq \max_{j \neq i} \left\{ \beta_i(\|x_i(0)\|, t), \gamma_{ij}(\|y_j\|_{[0,t]}), \gamma_i^u(\|u_i\|_\infty) \right\}$$

A digraph is employed to represent the gain interconnection structure of the dynamic network. The dynamic network is UO and IOS if the composition of IOS gains along every simple cycle in the gain interconnection digraph is less than the identity function.

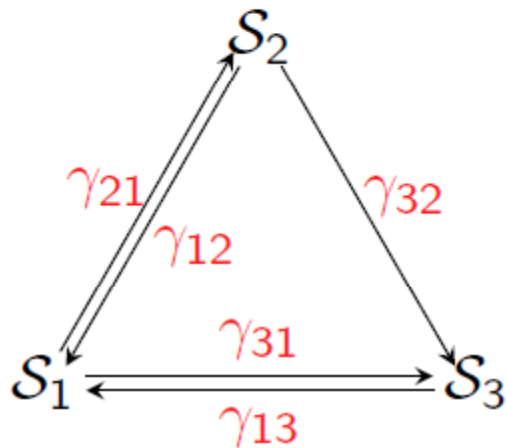

$$\gamma_{12} \circ \gamma_{21} < \text{Id}$$

$$\gamma_{13} \circ \gamma_{31} < \text{Id}$$

$$\gamma_{13} \circ \gamma_{32} \circ \gamma_{21} < \text{Id}$$

(cyclic-small-gain condition)

[Jiang & Wang 2008]

Lyapunov-based cyclic-small-gain results ; see [Liu, Hill & Jiang 2011].

NETWORKS WITH INTERCONNECTION TIME-DELAYS

Consider a dynamic network:

$$\begin{aligned}\dot{x}_1(t) &= f_1(x_1(t), x_2(t - \tau_{12}), x_3(t - \tau_{13}), \dots, x_n(t - \tau_{1n}), u_1(t)) \\ \dot{x}_2(t) &= f_2(x_2(t), x_1(t - \tau_{21}), x_3(t - \tau_{23}), \dots, x_n(t - \tau_{2n}), u_2(t)) \\ &\vdots \\ \dot{x}_n(t) &= f_n(x_n(t), x_1(t - \tau_{n1}), x_2(t - \tau_{n2}), \dots, x_{n-1}(t - \tau_{n(n-1)}), u_n(t))\end{aligned}$$

where $\tau_{ij} : \mathbb{R}_+ \rightarrow [0, \theta]$ for $i \neq j$ represents the interconnection delay from the j -th subsystem to the i -th subsystem with constant $\theta \geq 0$ being the largest time-delay.

Assume that each i -th subsystem with $\tau_{(\cdot)} \equiv 0$ is ISS with x_j for $j \neq i$ and u_i as the inputs:

$$\|x_i(t)\| \leq \max_{j \neq i} \left\{ \beta_i(\|x_i(0)\|, t), \gamma_{ij}(\|x_j\|_\infty), \gamma_i^u(\|u_i\|_\infty) \right\}$$

with $\beta_i \in \mathcal{KL}$, $\gamma_{ij}, \gamma_i^u \in \mathcal{K} \cup \{0\}$.

CYCLIC-SMALL-GAIN THEOREM FOR NETWORKS WITH INTERCONNECTION DELAYS [SEE TIWARI, WANG & JIANG' 12]

If the cyclic-small-gain condition is satisfied, then the dynamic network with interconnection time-delays is ISS:

$$|x(t)| \leq \max_{i=1,\dots,n} \left\{ \bar{\beta}(\|x(0)\|_{[-\theta,0]}, t), \bar{\gamma}_i^u(\|u_i\|_\infty) \right\}$$

with $\bar{\beta} \in \mathcal{KL}$ and $\bar{\gamma}_i^u \in \mathcal{K} \cup \{0\}$

Intuitively, since $|x_i(t - \tau_{ji})| \leq \|x_i\|_{[-\theta, \infty)}$,

one may consider the time-delay components as subsystems with **the identity gain**.

$$x_i \xrightarrow{\gamma_{ji}} x_j \quad \rightsquigarrow \quad x_i \xrightarrow{\text{Id}} x_i^{\tau_{ji}} \xrightarrow{\gamma_{ji}} x_j$$

SUBSYSTEMS WITH STATE TIME-DELAYS

Consider a dynamic network:

$$\dot{x}_i(t) = f_i(x_i(t), x_1(t - \tau_{i1}), \dots, x_n(t - \tau_{in}), u_i(t)), \quad i = 1, \dots, n$$

where $\tau_{ij} : \mathbb{R}_+ \rightarrow [0, \theta]$ represents the time-delays.

For $i = 1, \dots, n$, assume that system $\dot{z}_i = f_i(z_i, v_1, \dots, v_n, w_i)$ is ISS with v_1, \dots, v_n, w_i as the inputs:

$$|z_i(t)| \leq \max_{j=1, \dots, n} \left\{ \beta_i(|z_i(0)|, t), \gamma_{ij}(\|v_j\|_\infty), \gamma_i^w(\|w_i\|_\infty) \right\}$$

with $\beta_i \in \mathcal{KL}$, $\gamma_{ij}, \gamma_i^w \in \mathcal{K} \cup \{0\}$.

SUBSYSTEMS WITH STATE TIME-DELAYS (CONT'D)

The dynamic network is ISS if $\gamma_{ii} < \text{Id}$ for $i = 1, \dots, n$, and γ_{ij} for $i \neq j$ satisfy the cyclic-small-gain condition.

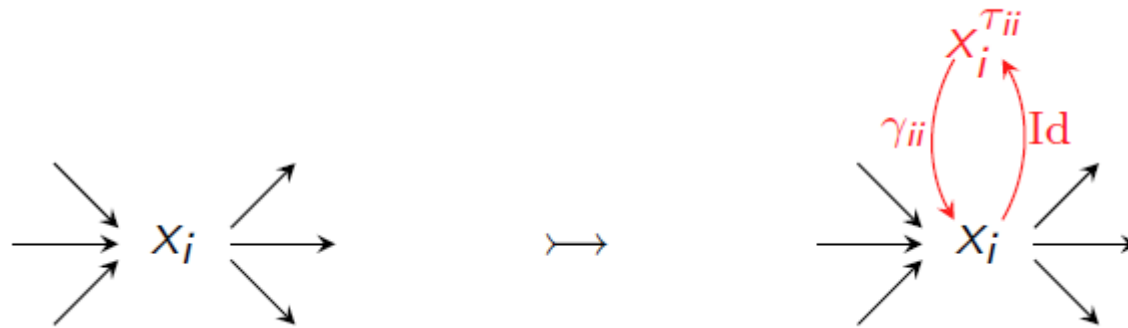

Remarks:

- When reduced to single systems, the small-gain result is in accordance with the Razumikhin-type result first developed in [Teel 98].
- There are also IOS cyclic-small-gain results for dynamic networks with time-delays [Karafyllis & Jiang 07], [Tiwari, Wang & Jiang 12]

SOME APPLICATIONS OF DISTRIBUTED CONTROL

- Sensor networks
[Ogren, Fiorelli & Leonard 2004]
- Coordination and formation control of vehicles
[Tanner, Jadbabaie & Pappas 2003], [Ren, Beard & Atkins 2007], [Jadbabaie, Lin & Morse 2003]
- Chemical processes
[Camponogara, Jia, Krogh & Talukdar 2002]
- Smart power grids
[Xin, Qu, Seuss & Maknouninejad 2011]

RECENT DEVELOPMENTS IN DISTRIBUTED CONTROL

- Lyapunov methods
[Lin, Francis & Maggiore 2007], [Shi & Hong 2009],
[Ogren, Egerstedt & X. Hu 2002]
- Passivity approach
[Arcak 2007]
- Linear algebra and matrix theory
[Fax & Murray 2004], [Cortes, Martinez & Bullo
2006], [Ren & Beard, 2007], [Qu, Wang & Hull 2008]
- Output regulation theory
[Wang, Hong, Huang & Jiang 2010], [Wieland,
Sepulchre & Allgower 2011], [Su & Huang 2012]
- “*Network Small-Gain theory*” (in this talk)

BACK TO THE DISTRIBUTED CONTROL PROBLEM

Each i -th agent ($1 \leq i \leq N$) takes the **disturbed output-feedback form**:

$$\dot{x}_{ij} = x_{i(j+1)} + \Delta_{ij}(y_i, w_i), \quad 1 \leq j \leq n_i$$

$$x_{i(n_i+1)} \triangleq u_i$$

$$y_i = x_{i1}$$

where $[x_{i1}, \dots, x_{in_i}]^T := x_i \in \mathbb{R}^{n_i}$ with $x_{ij} \in \mathbb{R}$ ($1 \leq j \leq n_i$) is the state, $u_i \in \mathbb{R}$ is the control input, $y_i \in \mathbb{R}$ is the (measured) output, $w_i \in \mathbb{R}^{n_{w_i}}$ represents external disturbances, and Δ_{ij} 's ($1 \leq j \leq n_i$) are unknown locally Lipschitz functions.

The dynamics of the agents may not be identical.

See, e.g., [Krstic, Kanellakopoulos & Kokotovic 1995] for early control results of systems in such form.

PROBLEM FORMULATION: OBJECTIVE AND ASSUMPTIONS

Objective: To develop a class of distributed controllers for the multi-agent system based on the available information such that

$$\lim_{t \rightarrow \infty} y_i(t) = y_0$$

for $1 \leq i \leq N$. y_0 is called agreement value.

Assumption: For the agreement value y_0 and the multi-agent system, there exists an $\Omega \subseteq \mathbb{R}$ such that

- $y_0 \in \Omega$;
- for each $1 \leq i \leq N$, $1 \leq j \leq n_i$,

$$|\Delta_{ij}(y_i, w_i) - \Delta_{ij}(y_{i'}, 0)| \leq \psi_{\Delta_{ij}}(\|[y_i - y_{i'}, w_i^T]^T\|)$$

for all $[y_i, w_i^T]^T \in \mathbb{R}^{1+n_{w_i}}$ and all $y_{i'} \in \Omega$, where $\psi_{\Delta_{ij}} \in \mathcal{K}_\infty$ is known.

If y_0 is available to each agent, then the problem can be easily solved with existing methods.

INFORMATION EXCHANGE TOPOLOGY

- **Neighbor:** If y_k is available for local control law design for agent i , then agent k is called a neighbor of agent i . We use \mathcal{N}_i to represent the set of indices of the neighbors of agent i .
- **Information exchange digraph \mathcal{G}** has N vertices corresponding to the N agents, and there is a directed arc from vertex k to vertex i if $y_k \in \mathcal{N}_i$.

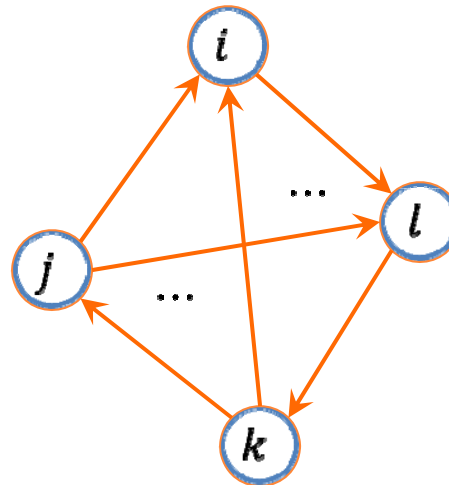

- **Leader and follower:** If y_0 can be used for the control law of agent i , then agent i is called a leader; otherwise, agent i is called a follower. Denote $\mathcal{L} \subseteq \{1, \dots, N\}$ as the index set of the leader agents.

INFORMATION EXCHANGE TOPOLOGY (CONT'D)

The local controller for each i -th agent will be designed by directly using y_i^m :

$$y_i^m = \frac{1}{N_i + 1} \left(\sum_{k \in \mathcal{N}_i} (y_i - y_k) + (y_i - y_0) \right), \text{ for } i \in \mathcal{L}$$

$$y_i^m = \frac{1}{N_i} \sum_{k \in \mathcal{N}_i} (y_i - y_k), \text{ for } i \in \{1, \dots, N\} \setminus \mathcal{L}$$

where N_i is the size of \mathcal{N}_i .

THE CASE OF $n_i = 2$

To reduce the complexity of discussions, we only consider agents with $n_i = 2$:

$$\dot{x}_{i1} = x_{i2} + \Delta_{i1}(y_i, w_i)$$

$$\dot{x}_{i2} = u_i + \Delta_{i2}(y_i, w_i)$$

$$y_i = x_{i1}$$

where $[x_{i1}, x_{i2}]^T := x_i$ is the state, $u_i \in \mathbb{R}$ is the control input, $y_i \in \mathbb{R}$ is the output, x_{i2} is the unmeasured portion of the state, $w_i \in \mathbb{R}^{n_{w_i}}$ represents external disturbances, and Δ_{i1}, Δ_{i2} are unknown locally Lipschitz functions.

Note: Our design is also valid for agents with different and/or higher orders.

A STATE TRANSFORMATION

Define $\dot{x}'_{i1} = \dot{y}_i - \dot{y}_0$, $\dot{x}'_{i2} = \dot{x}_{i2} + \Delta_{i1}(y_0, 0)$ and $\dot{x}'_{i3} = \dot{u}_i + \Delta_{i2}(y_0, 0)$
and introduce a dynamic compensator

$$\dot{u}_i = v_i.$$

Then,

$$\dot{x}'_{i1} = \dot{x}'_{i2} + \Delta_{i1}(y_i, w_i) - \Delta_{i1}(y_0, 0)$$

$$\dot{x}'_{i2} = \dot{x}'_{i3} + \Delta_{i2}(y_i, w_i) - \Delta_{i2}(y_0, 0)$$

$$\dot{x}'_{i3} = v_i$$

$$\dot{y}_i = \dot{x}'_{i1}$$

with the output tracking error $\dot{y}'_i = \dot{y}_i - \dot{y}_0$ as the new output and v_i as the new control input.

Note: If \dot{y}'_i is available, we can easily design an output-feedback controller for each agent to achieve the control objective by using existing methods. But \dot{y}_i^m instead of \dot{y}_i is available now.

LOCAL NONLINEAR OBSERVERS

$$\dot{\xi}_{i1} = \xi_{i2} + L_{i2}\xi_{i1} + \rho_{i1}(\xi_{i1} - y_i^m)$$

$$\dot{\xi}_{i2} = \xi_{i3} + L_{i3}\xi_{i1} - L_{i2}(\xi_{i2} + L_{i2}\xi_{i1})$$

$$\dot{\xi}_{i3} = v_i - L_{i3}(\xi_{i2} + L_{i2}\xi_{i1})$$

where $\rho_{i1} : \mathbb{R} \rightarrow \mathbb{R}$ is an odd and strictly decreasing function, and L_{i2}, L_{i3} are positive constants.

With the observer, $\xi_{i1}, \xi_{i2}, \xi_{i3}$ are estimates of $y_{i'}, x_{i2'} - L_{i2}y_{i'}$ and $x_{i3'} - L_{i3}y_{i'}$, respectively.

DISTRIBUTED NONLINEAR CONTROL LAWS

Using the estimates from the observer, the distributed control law for agent i is in the form of

$$e_{i1} = \xi_{i1}$$

$$e_{i2} = \xi_{i2} - \kappa_{i1}(e_{i1})$$

$$e_{i3} = \xi_{i3} - \kappa_{i2}(e_{i2})$$

$$v_i = \kappa_{i3}(e_{i3}).$$

where $\kappa_{i1}, \kappa_{i2}, \kappa_{i3}$ are continuously differentiable, odd, strictly decreasing and radially unbounded functions.

SOLUTION TO DISTRIBUTED OUTPUT-FEEDBACK CONTROL

If $\mathcal{L} \neq \emptyset$ and \mathcal{G}^c has a spanning tree with the leader agents as the roots, then with the proposed distributed observer and the distributed control law, all the signals in the closed-loop distributed system are bounded, and the outputs y_i 's can be steered to within an arbitrarily small neighborhood of y_0 . Moreover, if the system is disturbance-free, then each output y_i asymptotically converges to y_0 .

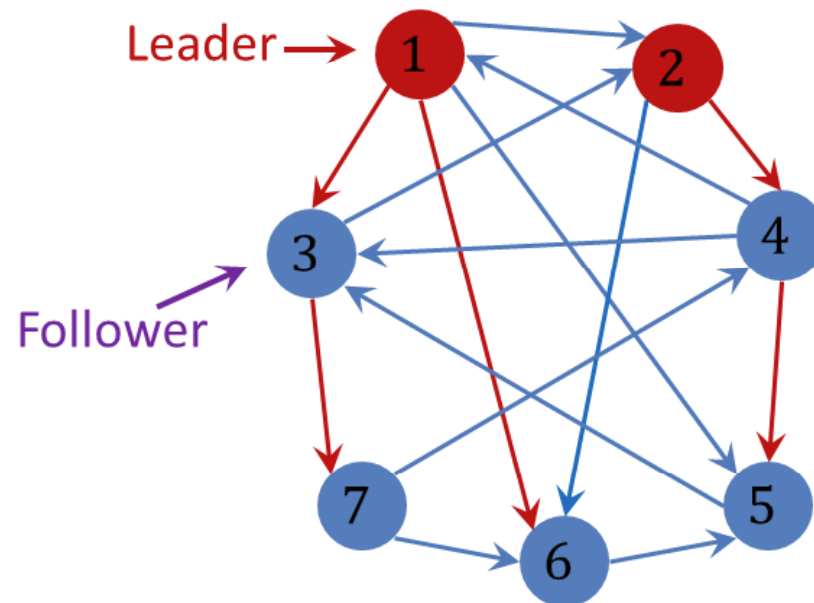

[Liu & Jiang 2013]

SKETCH OF PROOF: THE CONTROLLED AGENTS

By using the definitions of y_i^m and y_i' , we have

$$y_i^m = y_i' - \delta_i \sum_{k \in \mathcal{N}_i} y_k'$$

where $\delta_i = \frac{1}{N_i + 1}$ for $i \in \mathcal{L}$ and $\delta_i = \frac{1}{N_i}$ for $i \in \{1, \dots, N\} \setminus \mathcal{L}$.

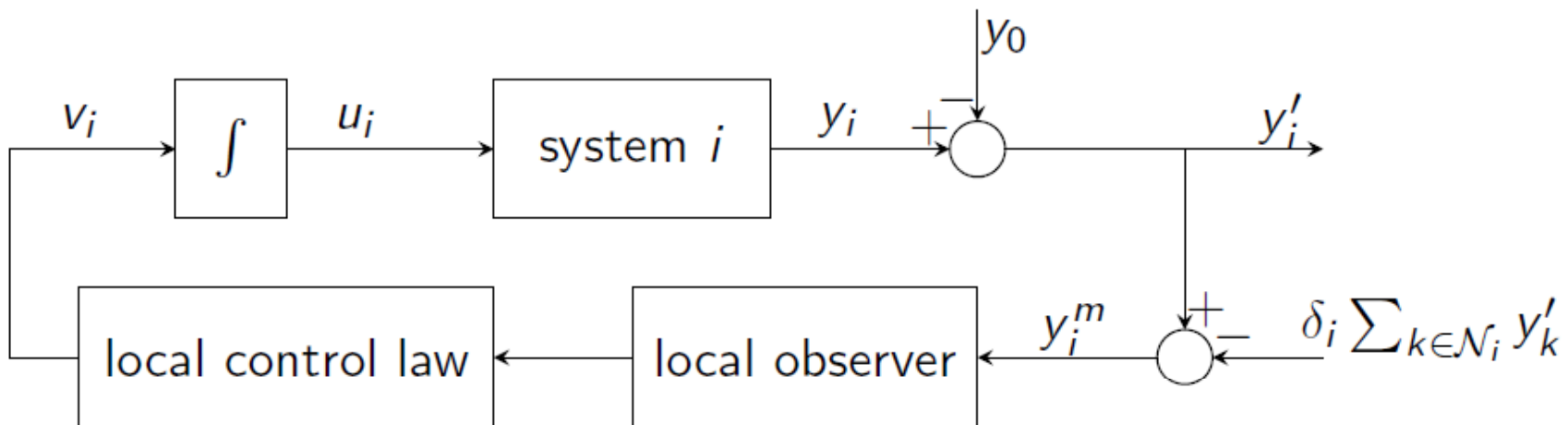

SKETCH OF PROOF: IOS OF EACH CONTROLLED AGENT

Denote $Z_i = [x_{i1'}, x_{i2'}, x_{i3'}, \xi_{i1}, \xi_{i2}, \xi_{i3}]^T$ as the internal state of the controlled agent system.

With the well designed distributed observers and distributed control laws, each nonlinear agent can be rendered to be UO and **IOS**, and satisfies

$$\begin{aligned}
 |y_{i'}(t)| &\leq \max \left\{ \beta_i(|Z_{i0}|, t), \frac{N_i}{N_i + 1} a_{ik} (\|y_{k'}\|_{[0,t]}), \gamma_i (\|w_i\|_{[0,t]}) \right\} \text{ for } i \in \mathcal{L}, \\
 |y_{i'}(t)| &\leq \max \left\{ \beta_i(|Z_{i0}|, t), a_{ik} (\|y_{k'}\|_{[0,t]}), \gamma_i (\|w_i\|_{[0,t]}) \right\} \text{ for } i \in \{1, \dots, N\} \setminus \mathcal{L}
 \end{aligned}$$

IOS gain

where $\beta_i \in \mathcal{KL}$, $\gamma_i \in \mathcal{K}_\infty$ can be designed to be arbitrarily small,
and $\sum_{k \in \mathcal{N}_i} \frac{1}{a_{ik}} \leq N_i$.

The closed-loop multi-agent system is a network of IOS systems.

A SMALL-GAIN RESULT IN DIGRAPHS

- Assign a_{ik} to the directed arc (k,i) in the information exchange digraph \mathcal{G}^c and denote A_o as the product of the a_{ik} along a loop O in digraph \mathcal{G}^c .

- For $i = 1, \dots, N$, the signal $y_i' = y_i - y_0$ practically converge to zero if
 - For each loop O through vertices $i \in \mathcal{L}$,

$$A_o \frac{N}{N+1} < 1 \quad (1)$$

- For each loop O not through any one of vertices $i \in \mathcal{L}$,

$$A_o < 1 \quad (2)$$

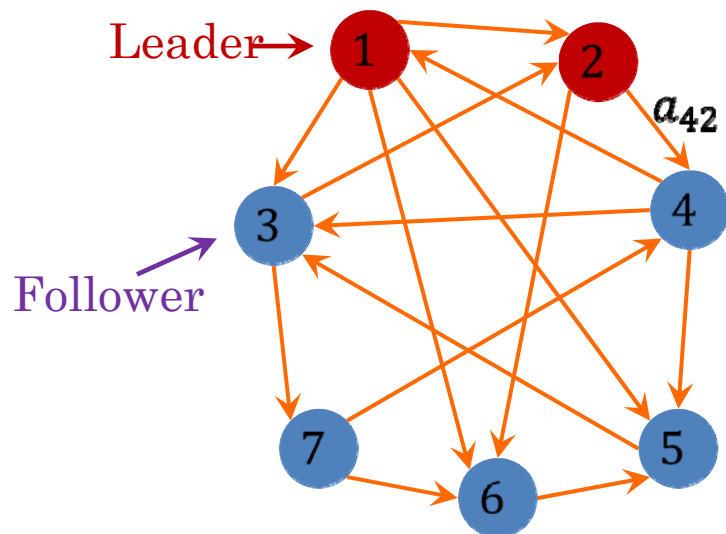

One can find appropriate a_{ik} $i \in \mathcal{L}$ to satisfy the cyclic-small-gain condition (1)-(2) if the digraph \mathcal{G}^c has a spanning tree with vertices as roots.

ROBUSTNESS TO TIME-DELAY

If there are information exchange delays, the y_i^m available to the control of agent i should be modified as

$$y_i^m(t) = \frac{1}{N_i + 1} \left(\sum_{k \in \mathcal{N}_i} (y_i(t) - y_k(t - \tau_{ik}(t))) + (y_i(t) - y_0) \right) \text{ for } i \in \mathcal{L}$$

$$y_i^m(t) = \frac{1}{N_i} \sum_{k \in \mathcal{N}_i} (y_i(t) - y_k(t - \tau_{ik}(t))) \text{ for } i \in \{1, \dots, N\} \setminus \mathcal{L}$$

where $\tau_{ik} : \mathbb{R}_+ \rightarrow \mathbb{R}_+$ represents time-delays of information exchange.

Suppose there exists a $\bar{\tau} \geq 0$ such that, for $i = 1, \dots, N$, $\tau_{ik}(t) \leq \bar{\tau}$ $k \in \mathcal{N}_i$ holds for all $t \geq 0$.

The main result of distributed output-feedback control still holds, based on the time-delay version of the cyclic-small-gain theorem.

CONCLUDING REMARKS

In this talk, we have introduced

- Several cyclic-small-gain results for dynamic networks with time-delays
- An application to distributed output-feedback control of uncertain nonlinear multi-agent systems

Future challenges in distributed control include

- Wider classes of nonlinear systems
- Systems with physical interconnections
- Applications to multi-vehicle systems, smart power grids, etc.

Acknowledgements:

- BIT
- Jie Chen + Wei Ren
- T. Liu (东北大学“百人计划”特聘教授)

Thank You !